

FME Tracking Solutions

a Diversified Diamond Products Company

FME Tracking Solutions powered by CribMaster Accu-Drawer

Imagine that an employee with a defined work order walks up to a cabinet in an area or zone that stores tooling, spare parts, safety equipment, maintenance kits or even haz-mat materials. Like all of our CribMaster point-of-use devices, an authorized employee is required to identify himself or herself. The drawer unlocks using an electro magnetic lock and inside are the items they need to complete their task. Each item is directly tagged with a passive Gen2 RFID tag or the location is monitored with a patent pending RFID switch. When the item is removed, inventory is automatically adjusted and monitored through FME Tracking Solutions powered by CribMaster.

The Accu-Drawer is a great solution for process improvement and accountability. One way to have a high impact is to build pre-outage maintenance kits and reserve inventory for them. This system will ensure the inventory is on hand and is ready to go in pre-built kits at point-of-use with all the supplies needed to perform the maintenance routine. The Accu-Drawer provides 100% positive tool control with complete accuracy. The toolboxes (Accu-Drawers) can be wheeled into the FME zones, or they can be placed out in front of the choke points into the zones. Shut-down time is drastically reduced.

Nuclear facilities that choose to implement this system can create a Standardization of Tools and Equipment Accountability during Outages (USA/STARS). Utilizing the processes of FME Tracking Solutions powered by CribMaster in one location can easily be duplicated in any other facility across the country. This will eliminate duplicate training as well as tool and equipment issues.

The FME Tracking Solutions powered by CribMaster Accu-Drawer brings many functions, features and benefits for outage management:

- Reduction in workforce labor to manage process
- All-inclusive Material Accountability Tracking System (MATS)
- Configurable drawer sizes allow for multiple product sizes
- Create and build pre-outage maintenance kits at point-of-use
- Equipment certification and compliance notification
- Durable 100% made in the USA 16 gauge steel construction
- Reduce shrinkage due to lost, stolen, or misplaced tools
- Touch screen control allows for User ID log-in
- Complete work order system and ability to track inventory to work orders
- Improved inventory accuracy for FME processes
- Reduced work delays

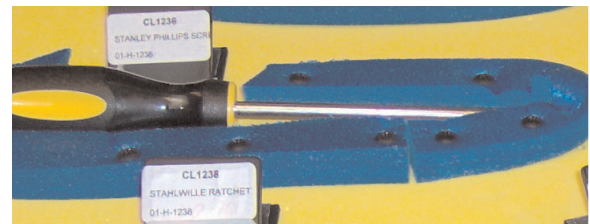
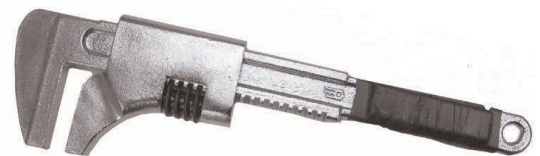

Microsoft
CERTIFIED
Partner

ISV Software Solutions

Headquarters: 4541 N. 12th Street Phoenix, AZ 85014 phone 800.336.9959
fax 480.483.1673 www.diversifieddiamond.com - sales@diversifieddiamond.com



Available Sizes

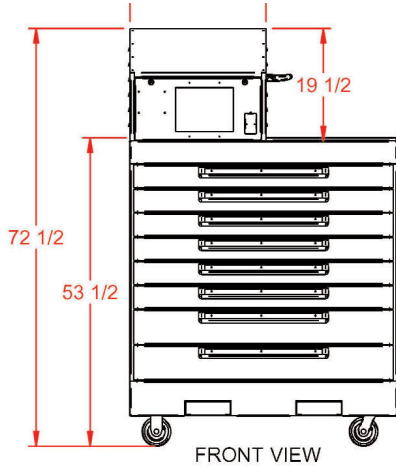

The Original Accu-Drawer
8 Drawers
72.5" Tall x 46.25" Wide x 28.5" Deep

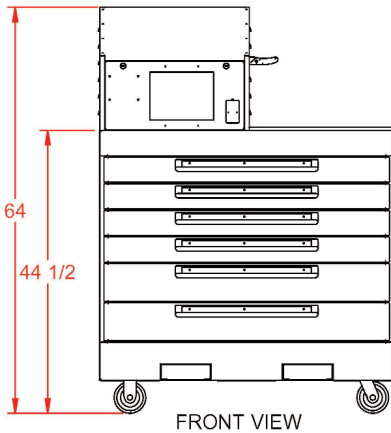

The Accu-Drawer Mini
6 Drawers
64" Tall x 46.25" Wide x 28.5" Deep

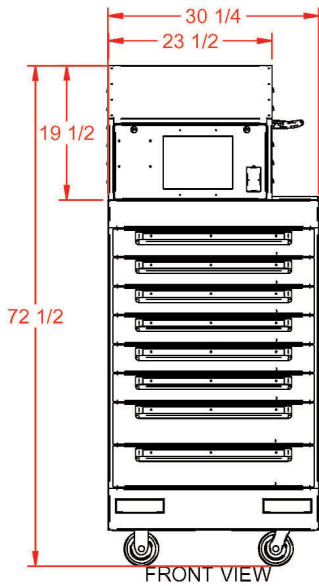

The Accu-Drawer Mobile
8 Drawers
72.5" Tall x 30.25" Wide x 28.5" Deep

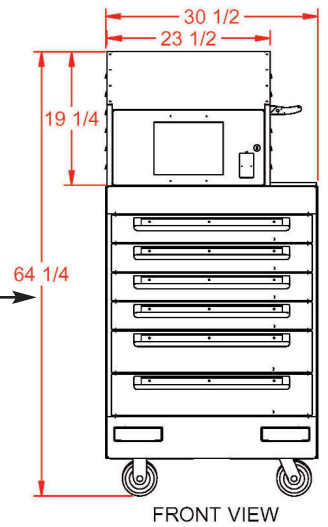

The Accu-Drawer Mini Mobile
6 Drawers
64.25" Tall x 30.5" Wide x 28.5" Deep

Included Accessories

8 Drawer Units (Original & Mobile)

RFID Tags on Switches	200
Foam Screws	500
Blue Foam Strips .5 x .75 x 48	30
Blue Foam Strips .75 x .75 x 48	12

6 Drawer Units (Mini & Mobile Mini)

RFID Tags on Switches	150
Foam Screws	400
Blue Foam Strips .5 x .75 x 48	25
Blue Foam Strips .75 x .75 x 48	10

